

INSTRUCTION BOOK

for the

Royal Enfield

'Made like a Gun'

1958-59

"CONSTELLATION,"

"SUPER METEOR,"

"METEOR MINOR" de Luxe and

"METEOR MINOR" Standard

MOTOR CYCLES

Price 2/-

INSTRUCTION BOOK

for the

Royal Enfield

★ ★ 'Made like a Gun' ★

1958-59

“CONSTELLATION,”

“SUPER METEOR,”

“METEOR MINOR” de Luxe and

“METEOR MINOR” Standard

MOTOR CYCLES

THE
ENFIELD CYCLE COMPANY
LIMITED

Head Office and Works:
REDDITCH, WORCESTERSHIRE

Telegrams :
“Cycles, Phone, Redditch”

Telephone :
Redditch 121 (9 lines)

CONTENTS

	Page		Page
FOREWORD	3	Re-assembling the Engine	30
OPERATION		after Decarbonising	31
The Controls	3	Tappet Adjustment	31
Starting the Engine	7	Completing Assembly after	
Driving Instructions	7	Decarbonising	32
Running-in	9	Removal of Engine from the	
LUBRICATION		Frame	32
Action of the Oil Pump	12	Fitting the Alternator	33
Engine Lubrication Routine	12	Removal of Engine and Clutch	
Multi-grade Oils	14	Sprockets	33
Detergent Oils	14	Ignition System	34
Lubrication of Gearbox	16	Timing Chain Adjustment	36
Lubrication of Chains	16	Magnetto Chain Adjustment	
Grease Gun Lubrication	16	("Constellation")	38
Lubrication of Front Forks	18	Sparking Plugs	38
Lubrication of Rear Suspension Units	18	Lighting Set	41
ROUTINE ADJUSTMENTS		Carburettor	42
Clutch Control	19	Air Cleaner	43
Chain Adjustment	20	TRANSMISSION	
Rear Chaincase Removal	21	Enfield Four-Speed Gear	44
Brake Adjustment	22	Clutch	44
Steering Head Adjustment	23	Patent Cush Drive Rear Hub	45
TROUBLE ON THE ROAD		TELESCOPIC FRONT FORK	
Engine Stops owing to lack		Construction	46
of Petrol	24	Dismantling	48
Engine Misfires or Stops		REAR SUSPENSION	48
owing to faulty Ignition	24	MISCELLANEOUS	
Other Causes of Engine		Removing Camshafts ("Con-	
Stoppage	25	stellation")	49
Clutch Trouble	26	Brakes	49
OVERHAULING THE ENGINE		Wheel Removal	50
Decarbonising	26	Removal of Rear Mudguard	
Cylinder Head Removal	26	Unit... ..	50
Removal of Valves	27	Quickly Detachable Rear	
Removing the Carbon	28	Wheel Removal	51
Piston Removal	29	Fitting a New Rear Chain	53
Grinding-in Valves	29	Removal of Tyres	53
		"DON'TS" FOR DRIVERS	55
		GUARANTEE	56

"CONSTELLATION," "SUPER METEOR" AND "METEOR MINOR"

ILLUSTRATIONS

Fig. No.	Description	Page
1a	Plan of the Controls ("Constellation")	5
1b	Plan of the Controls ("Super Meteor" and Meteor Minor")	6
2	Lubrication System	10
3	Draining the Oil Tank and Pump	11
4	Clutch lever and cable adjustments ("Super Meteor")	17
5	Clutch adjustments ("Constellation" and "Meteor Minor")	17
6	Gearbox Oil Filler and Level Plugs	18
7	Primary Chain Adjustment	21
8	Rear Chain Adjustment	22
9	Clamp Bolts securing the Steering Stem and Fork Tubes	23
10	Removing Steel Thimbles or End Caps, when removing valves	26
11	Using a suitable Valve Spring Compressing Tool	27
12	Tapping out Gudgeon Pin	28
13	Tappet Adjuster	30
14	Timing Marks	35
15	Timing Chain Adjustment	37
16	Wiring Diagram ("Constellation")	39
17	Wiring Diagram ("Super Meteor" and Meteor Minor")	40
18	Assembling Cush Drive Hub	45
19	Telescopic Front Fork ("Constellation" and "Super Meteor")	47
20	Telescopic Front Fork (1959 "Meteor Minor")	47
21	Telescopic Front Fork (1958 "Meteor Minor")	47
22	Rear Wheel Adjustment where Chaincase is fitted	50
23	Quickly Detachable Rear Hub	52

“Constellation,” “Super Meteor” and “Meteor Minor”

OPERATION

- 1 **Foreword.** Basically, the design of the “Constellation” follows that of the “Super Meteor.” Except where otherwise specified, the general instructions given in this book apply to the “Constellation,” “Super Meteor” and “Meteor Minor.”
- 2 Operation of the controls should be practised and their positions learned so thoroughly that the necessary movements are performed instinctively without any fumbling or time lag. The following remarks will give added assistance to the uninitiated.

“**Constellation.**” This model has magneto ignition, the control of the ignition point is manual instead of being automatic. Therefore, a magneto control lever is added to the left handlebar (see Fig. 1a).

Again, in view of the superior performance of this machine and the uses to which it is likely to be put, a steering damper is included, operated by a wing nut from the top of the steering head above the instrument “Casquette.”

“**Super Meteor**” and “**Meteor Minor.**” The arrangement of the controls for these models is shown diagrammatically in Fig. 1b on page 6.

Gear Control. Move the foot lever up to change to a lower gear and down to change to a higher gear.

Neutral Finder. Neutral position from second, third or top gear is found by pressing the lever downwards as far as it will go, keeping the machine rolling and lifting the clutch meanwhile.

“CONSTELLATION,” “SUPER METEOR” AND “METEOR MINOR”

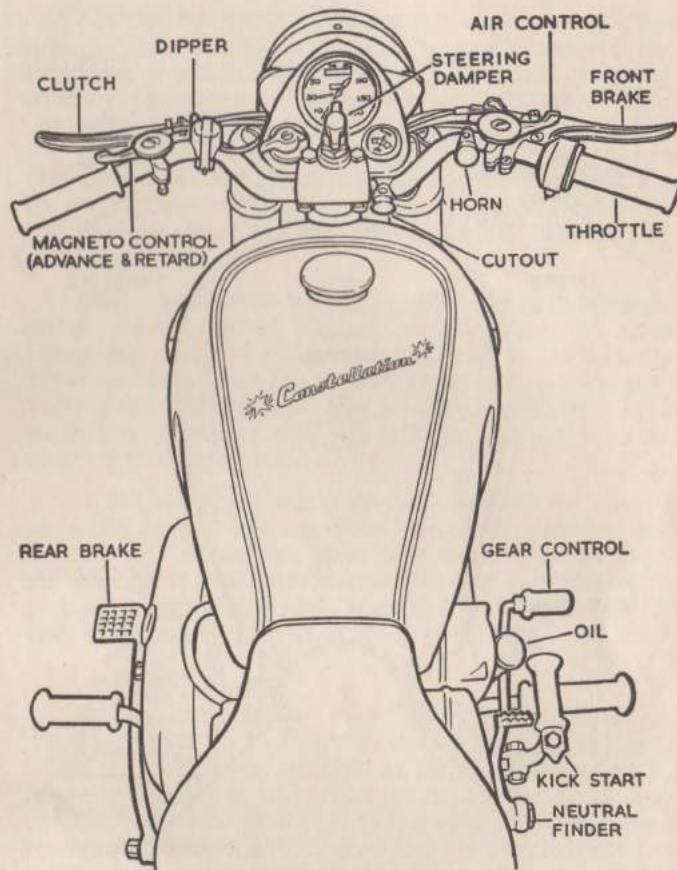

Fig. 1a—Plan of the Controls (“Constellation”)

Petrol and Oil Filler Caps. To remove the cap, turn it anti-clockwise until resistance is felt, then press down and continue turning as far as possible until cap is freed.

To replace, press the cap down and turn clockwise as far as it will go.

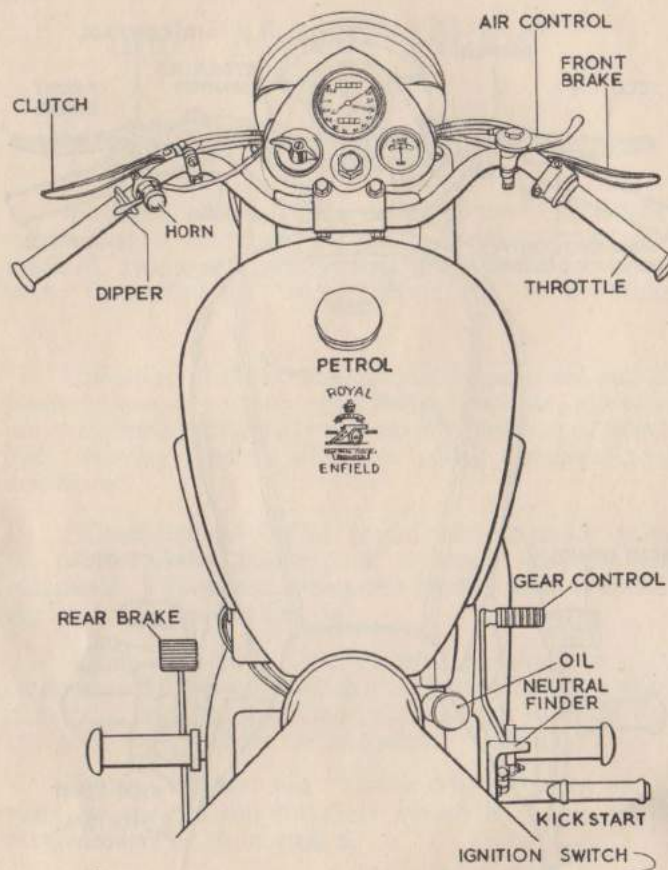

Fig. 1b—Plan of the Controls ("Super Meteor" and "Meteor Minor")

Petrol Tap. The two-level tap beneath the near side of the tank is opened by pushing the hexagon-shaped end, and closed by pushing the round end. To retain the reserve supply of fuel, move the small lever above the tap anti-clockwise; the reserve supply is released by moving the lever clockwise.

3 Starting the Engine. Before starting a new machine, or any machine which has come into your possession for the first time, check the oil levels in the crankcase, gearbox, and primary chain case. Having been satisfied that these are correct and that there is sufficient fuel in the tank, turn on the petrol as described above and observe that the reserve supply lever above the tap is turned anti-clockwise against its stop. Depress the tickler of the carburettor momentarily, two or three times, but cease this "tickling" should flooding be observed.

Open the throttle by turning the twist grip towards you about one-quarter of its full travel. Close the air lever completely and give a firm swinging kick to the kick starter. If two or three kicks fail to start the engine, experiment with varying throttle openings until results are achieved. Different engines may require different settings and a few trials will discover the correct one.

When starting a warm engine leave the air lever open, or partly open. Do not flood the carburettor or the fuel mixture will become too rich. Do not race an engine when the machine is stationary, a brief burst of acceleration to test pick-up is permissible, but sustained high engine speed can only be harmful under these conditions.

4 Driving Instructions. To set the machine in motion, lift the clutch lever to its fullest extent and engage first gear by lifting the gear lever upwards as far as it will go and then releasing it when it will return to its normal position ready to select the next gear. Now gradually release your grip on the clutch lever and, as you feel the clutch begin to take up the drive, gently open the throttle until the clutch is fully home. In this way, by judicious synchronisation of the clutch and throttle operation, the machine will move away smoothly.

Allow the machine to reach, say, 12 m.p.h. and change up to second gear by lifting the clutch and, at the same time, closing the throttle. Depress the gear lever to its fullest

extent and release it again; engage the clutch and re-open the throttle. Repeat this operation at about 25 m.p.h. to engage third gear and again at 35 m.p.h. for changing to top gear.

The above speeds are intended only as a rough guide for use on flat roads under normal conditions. Starting on a hill will, of course, require rather more throttle, depending on the severity of the gradient, and changing to a higher gear on a hill should only be done at a speed high enough to avoid labouring of the engine.

Except in very cold weather, it will be found that, after a few moments running at a comfortable speed, the air lever can be fully opened and left there for the remainder of the run. Do not close the air lever to relieve a labouring engine on a hill, change to a lower gear instead.

Never hold on to a high gear on a hill to the point where “pinking” sets in, give the engine a chance to develop its true character by using the gearbox.

In changing from a high gear to a lower one, it will be necessary to speed up the engine slightly with the clutch lifted just before operating the gear lever. By leaving the throttle control alone, the very act of de-clutching will cause the engine to accelerate and this may be all that is required to effect a smooth change. A little experiment at varying speeds and in the different gears will show the correct course to follow, but the uninitiated should note that when changing **up** engine speed should be reduced, and when changing **down** it should be increased. When the engine speed is correctly judged there will be no snatch as the clutch goes home.

To stop the machine, close the throttle, apply the brakes and, as the machine comes to rest, lift the clutch, and select neutral position by pressing downwards on the neutral finder lever with the heel.

If the Works carburettor setting has not been disturbed, it will be found that, with the twist grip fully closed, the engine will tick over gently. In these circumstances, the engine must be stopped by switching off the ignition.

5 Running In. Careful handling of an engine in the early stages is imperative if satisfactory subsequent running is to be achieved. Oval, slotted pistons, fitted to Royal Enfield engines minimise the risk of seizure, but abuse can cause damage which may affect the performance and the life of an engine.

It is recommended that a new machine should not be driven at a speed in excess of 35 m.p.h. for the first 200 miles, and on no more than half throttle until 500 miles have been covered.

Short bursts of wider throttle openings than this will do no harm, and after 500 miles, may be made more frequently in order to hasten the bedding down of the thrust faces of the pistons.

By a gradual increase of speeds, the engine will be conditioned to withstand prolonged, wide throttle openings and, indeed, by progressively increasing the work done by the engine there is greater assurance of securing better performance and more lasting results than by slavishly keeping down to 30 m.p.h. for 1,000 miles.

Too long a period, in the early stages, on full throttle, or shortage of oil by neglect, may lead to a seizure. Should the slightest tendency to pull up be noticed, close the throttle and release the clutch immediately. Most likely, if this is done, the piston will free itself in a few minutes and the journey may be continued more gently. However, after any such happenings it is essential that the piston and cylinder be examined by a **competent** mechanic and any high spots relieved.

Always remember that good driving is the first—and by no means the least important—act of maintenance. Fierce acceleration, satisfying and showy though it may be to some people, places an undue strain on engine and transmission. Leaving the braking to the last minute and applying the brakes viciously is harmful to the machine and tyres, besides being dangerous. If you will make your progress as unobtrusive as possible—and this doesn't mean slow travel—not only will you earn the goodwill of the general public, but you will enjoy many more carefree miles of motor cycling.

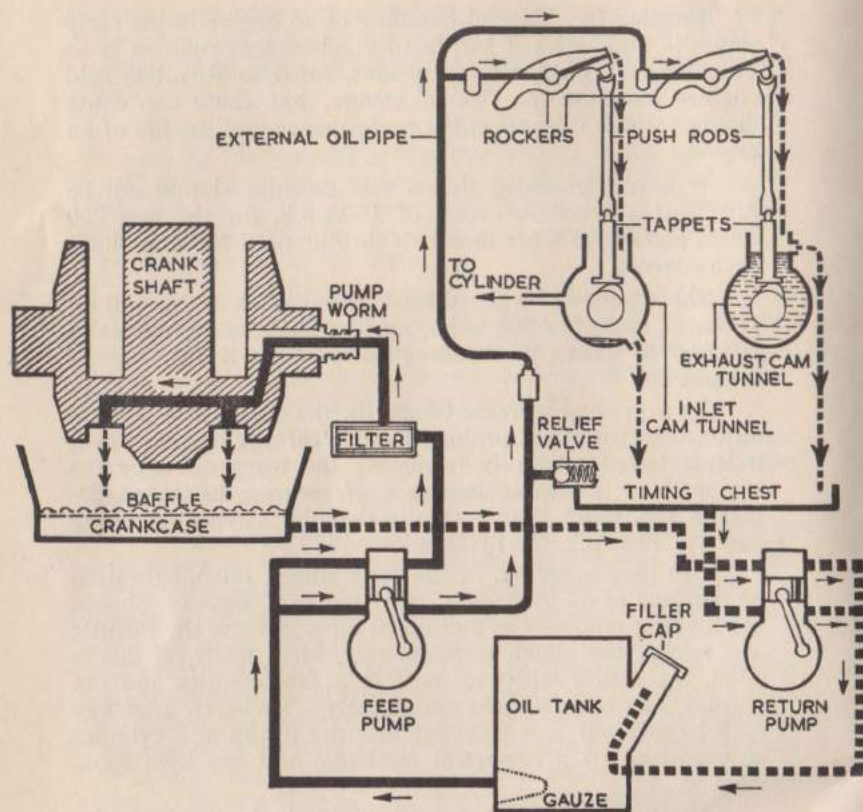

Fig. 2—Lubrication System.

LUBRICATION

6 Lubrication is of the dry sump type and oil is carried in a tank cast integral with the crankcase. A feed pump and a return pump, each of the plunger type, are operated by a common spindle, driven by a worm gear from an extension of the crankshaft.

Oil is drawn from the oil tank by the feed pump through a strainer and passed on by the primary side of the pump through a filter and through holes drilled in the crankshaft to the big-end bearings. From this point the oil is splashed on to the cylinders, pistons and main bearings. The secondary side of the feed pump delivers oil through a drilled passage in the crankcase from which external pipes take it to the overhead valve rockers.

The oil which has been used for lubricating big-end bearings, cylinder and pistons, drains into a well in the base of the crankcase from which it is picked up by the return pump and passed back to the tank.

The oil from the rocker gear drains down the push rod tubes to the tunnels which house the camshafts. Some oil drains from the inlet camshaft tunnel through holes drilled

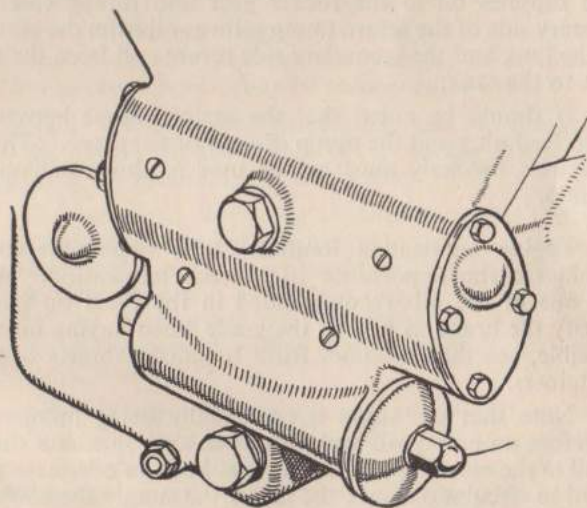

Fig. 3—Draining the Oil Tank and Pump. Passing through the oil pump casing is the main feed plug to the big ends. Below the pump chamber is the felt oil filter while, below this and in the crankcase, is the drain plug.

in the lower ends of the cylinder barrels, providing additional lubrication for the pistons. Most of the oil from the inlet camshaft tunnel and all of that from the exhaust camshaft tunnel drains to the timing case, whence the return pump picks it up and returns it to the tank.

- 7 **Action of the Oil Pump.** Each end of the oil pump drive spindle terminates in an eccentrically mounted peg which works in a hole drilled through the end of each pump plunger. These plungers slide in bored holes or cylinders in small blocks—or discs as they are termed—which fit into housings, being held in position there by short coil springs, the outer ends of which press against domed metal pads located in the oil pump case covers.

The primary side of the double-acting feed pump supplies oil to the big-end, piston and main bearings and the secondary side supplies oil to the rocker gear and timing case. The primary side of the return pump returns oil from the crankcase to the tank and the secondary side returns oil from the timing case to the tank.

It should be noted that the sealing sleeve between the main feed plug and the pump drive is of neoprene. The cork type used formerly must not be used at this point on these engines.

- 8 **Engine Lubrication Routine.** It is impossible to over emphasise the importance of correct lubrication. Always use one of the oils recommended in the chart on page 14, specify the brand as well as the grade when buying oil and, if possible, see that it comes from branded cabinets or sealed containers.

Note that the sump is continually being pumped dry, therefore an empty oil tank results in an immediate shortage of oil to the working parts. Always keep an adequate supply of oil in circulation since the larger the supply the cooler will be the oil and the longer will it retain its lubricating qualities. Do not, however, fill the oil tank to a higher level than 2 in. below the top of the filling orifice, and always keep it well above the bottom of the dipstick.

During the running-in period, an addition to the engine oil of running-in compound, containing Acheson's Colloidal Graphite, is recommended.

After the first 500 miles and, subsequently, about every 2,000 miles, the tank, sump, timing case and felt filter chamber should be drained. Drain the tank and pump by removing the plug which has a large hexagon head and is to be seen at the bottom of the crankcase on the offside just below the oil filter housing, see Fig. 3.

Draining will be quicker if carried out at the end of a run while the oil is warm, and more economical if a moment is chosen when the oil is fairly low in the tank.

The element of the felt oil filter should be removed and washed in petrol after the first 500 miles and every subsequent 2,000 miles. Fit a new element every 5,000 miles.

A small circular magnet is also fitted over the fixing stud inside the oil filter for the purpose of collecting any ferrous particles which may be suspended in the oil.

Oil is drained from the timing case by removing the feed plug from the lower face of the timing case cover and then lying the machine over on its side.

The main oil feed plug screwed into the timing case cover abuts against a rubber oil seal located in a recess in the oil pump worm nut. It is important that this be preserved in first class condition and a new one should be fitted if the state of the existing one is at all doubtful. Any leakage at this point will, among other things, result in starvation of the engine bearings.

After draining the timing case, no oil will be returned from it to the tank until the normal timing case level has been restored. Similarly, after draining the felt oil filter chamber, no oil will be returned from this point to the tank until the oil pump has refilled the chamber. For these reasons, the initial running of the engine after draining operations will lower the level of oil in the tank. Make sure that this level is high enough to ensure proper circulation.

RECOMMENDED LUBRICANTS

	Castrol	Mobiloil	Esso Extra Motor Oil	B.P. Energol	Shell X-100 Motor Oil
Engine (summer)	XXL	BB	40/50	S.A.E.40	40
Engine (winter)	Castrolite	A	20W/30	S.A.E.30	30
Gearbox	XXL	BB	40/50	S.A.E.40	40
Chains—front	Castrolite	Arctic	20W/30	S.A.E.20	20
rear	XXL	BB	40/50	S.A.E.40	40
Grease Gun	Castrolite (Heavy)	Mobilgrease (No. 4)	Esso Grease	Energol C.3	Retinax A
Front Forks	Castrolite	Arctic	20W/30	S.A.E.20	20

9 Multi-grade Oils. Some of the manufacturers of the lubricants in the table above offer special engine lubricants, the viscosity of which is less sensitive than usual to temperature changes. These are classed as S.A.E. 10W/30 or 10W/40 oils. Their use will facilitate starting at low temperatures but may result in an increase in the rate of oil consumption. These oils are all of a highly detergent nature and the precautions given in paragraph 10 should be followed if a change to them is made after a long period of use on a non-detergent oil.

Castrolite and Esso Extra Motor Oil are of a mild multi-grade character (S.A.E.20W/30) and have only mild detergent properties. They are therefore especially recommended for winter use if difficulty is experienced with starting owing to the gumminess of normal S.A.E.30 oils when cold and if the owner does not wish to take the precautions necessary when changing to a highly detergent oil.

10 Detergent Oils. Many of the oils which we recommend contain detergent additives designed to counteract ring sticking and sludge formation.

The degree of detergency varies not only between one make and another but in some cases between different grades of the same make and may even be different for the same grade and make of oil in different parts of the world.

If one of the more highly detergent oils is used in an engine containing large deposits of sludge which have accumulated when running on another grade of oil this sludge will be loosened and may cause seizure and other trouble due to blockage of filters and oilways.

For this reason the following procedure should be carried out when changing to one of the more highly detergent oils, particularly if the engine has been used on a normal grade of oil or has not had the oil drained and changed at regular intervals as recommended in paragraph 8.

- (1) Drain the engine when the oil is hot and refill with the detergent oil.
- (2) Run the machine at a moderate speed for not more than 50 miles.
- (3) Drain the engine again when the oil is hot, flush out the oil tank with detergent oil, remove, clean and replace filters (preferably fit new felt filter element). Refill with detergent oil.
- (4) When machine has run a further 100 miles check condition of filters. If clogged, repeat operation (3).

Note. Although the detergent additive in the oil keeps the engine clean and prevents sludge formation, it naturally becomes used up in the process. If an engine has a very low oil consumption so that "topping up" is seldom (if ever) necessary, the additive may all become used up, in which case sludge formation will occur at the normal rate. It is therefore just as important to drain the engine at regular intervals with a detergent oil as with one having no detergent additive.

Your dealer will advise you which makes and grades of oil in your country have sufficient detergency to necessitate the above enumerated precautions being taken.

11 Lubrication of Gearbox. Pour the grade of oil shown in the table on page 14 through the filler hole on top of the gearbox until the oil overflows from the level plug hole on the front or the back of the gearbox. The level plug must, of course, be removed for this and the machine should be on an even keel on level ground. Replace both plugs.

12 Lubrication of Chains. To lubricate the front chain, remove the filler plug and the smaller overflow plug, and pour in oil until it commences to overflow. Again, keep the machine upright and level when doing this.

Engine oil or grease may be used on the rear chain, but do not use an excessive quantity or much of it will merely be thrown on to the roadway, to other parts of the machine and on to your clothing. It is a good plan, after say, every 2,000 miles to remove the chain, wash it well in paraffin, leave it to drain thoroughly and then immerse it in molten tallow or grease. Allow the tallow to set, remove the chain, wipe away surplus lubricant and refit. The enclosed chain of the “Meteor Minor” de Luxe should have frequent applications of engine oil.

13 Grease Gun Lubrication. The rear brake pedal, gear control, speedometer drive and rear suspension pivot should be greased with a grease gun every 500 miles; and the clutch push rod well lubricated before reassembly. The grease nipples for the rear suspension pivot are at each end of the spindle, which is drilled for the grease. For the correct grade of grease, refer to the chart on page 14.

Grease the hubs only very sparingly; there must be no possibility of grease finding its way into the brakes, but should this inadvertently happen, remove the brake shoes, scrape the linings thoroughly, wash in petrol, clean the brake drums, and re-assemble.

Note. With the re-designed clutch on the “Constellation” and “Meteor Minor” it is not necessary to grease the clutch push rod; neither is grease gun lubrication provided for the wheel hubs.

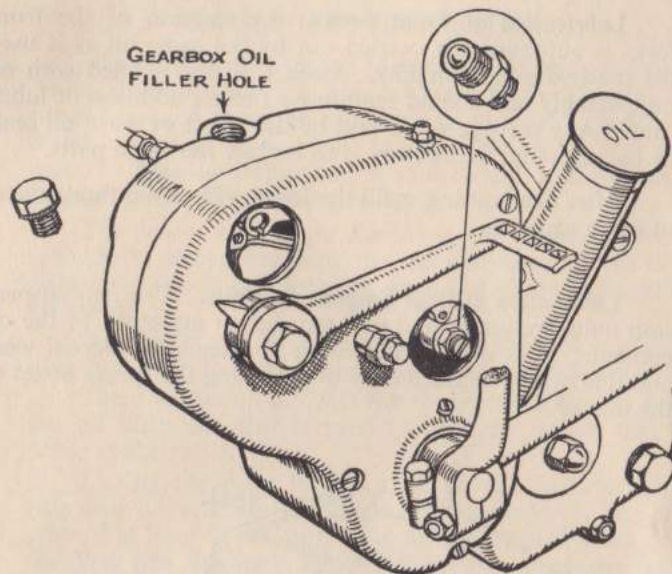

Fig. 4—Clutch lever and cable adjustments (“Super Meteor”).

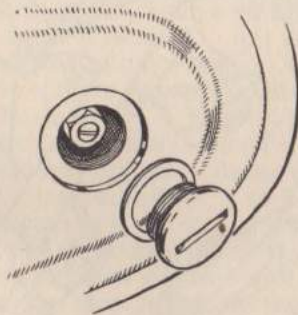

Fig. 5—Clutch adjustments (“Constellation” and “Meteor Minor”)

Slacken the locknut and turn the screw in the desired direction to give correct clearance for clutch operation.

- 14 Lubrication of Front Forks.** Lubrication of the front forks is automatically carried out by the same oil as is used for the hydraulic damping. Each fork leg is filled with oil on assembly and should require no further addition of lubricant. Any seepage of oil will be the result of worn oil seals or bearings and the remedy is to replace the worn parts.

After dismantling, refill the forks with seven fluid ounces of oil in each leg.

- 15 Lubrication of Rear Suspension Units.** The rear suspension units are sealed and will require no attention to the oil content. Loss of oil will be due to excessive internal wear and this can be rectified only by returning the spring boxes to the makers.

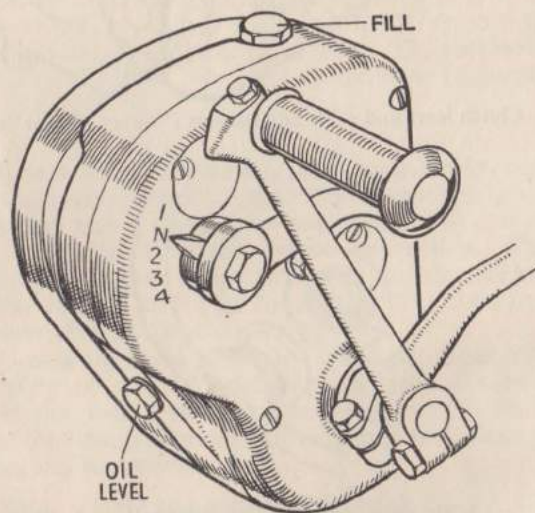

Fig. 6—Showing oil filler and level plugs on gearbox. This illustration depicts the oil level plug at the back of the gear-box.

ROUTINE ADJUSTMENTS

- 16 Clutch Control ("Super Meteor").** On the gearbox end cover are two inspection holes covered by metal discs. The upper one of these gives access to the cable end of the clutch operating lever which should have $\frac{1}{16}$ in. free movement. This is important if clutch slip and subsequent damage to the clutch plates are to be avoided.

The lower hole gives access to the adjustment which is made by slackening back the nut and screwing the slotted adjuster inwards or outwards until the desired clearance is obtained.

It is important to keep the end of the clutch push rod and the ball in the end of the adjuster screw well greased.

There is also an adjuster for the clutch cable just behind the oil filler and this is used to take up stretch that may occur in the cable.

During the early life of a clutch the friction material may bed down fairly rapidly so that clearance in the clutch control is lost. Therefore, keep an eye on this point during the first few hundred miles, making any necessary adjustment.

Clutch Control ("Meteor Minor" and Constellation"). Precise adjustment of the clutch control must be maintained if drag or slip are to be avoided. It is important to note that with the clutch fitted to the "Meteor Minor" and "Constellation" machines there are two points of adjustment, and each one must be correct.

First, there is the actual clutch operating adjustment. By using the mid-way adjuster, slacken off the cable adjustment. Remove the plug which is to be found towards the rear of the chaincase; this will reveal the withdrawal pin with locknut. Slacken the locknut and, by means of the slotted end, turn the withdrawal pin half-a-turn or so clockwise in order to ensure that there is slack in the withdrawal mechanism. Then turn the pin anti-clockwise until resistance is felt; there is now no play in the withdrawal mechanism. Now turn the pin a third to half-a-turn clockwise and, holding it in this position, tighten the locknut. To hold the

screw whilst tightening the locknut, insert a screwdriver through the tubular spanner on the locknut. The tubular spanner can easily be turned by hand to take up play, after which the screwdriver can be removed and final tension applied by using a tommy bar.

Secondly, there is the clutch cable; adjustment must be made by means of the midway cable adjuster, to give about $\frac{1}{8}$ " free movement at the hand lever before clutch spring tension is felt.

- 17 **Chain Adjustment.** Access to the primary chain adjustment is gained by removing the chain cover which is held in place by a single nut. Have a tray handy to catch the oil as the cover is removed. Beneath the bottom run of the chain is a curved slipper on which the chain rests. This may be raised or lowered by turning the adjusting screw after first having slackened its locknut. Do not adjust the chain dead tight but revolve the engine slowly and while doing so, test the tension of the top run of the chain by pressing it up and down with the fingers. Note whether the chain is tighter at some spots than at others and adjust the tension so that there is $\frac{1}{4}$ in. up and down movement at the tightest spot. This amount of slack should be present all round if there are no tight spots. Re-tighten the locknut on the adjusting screw, replace the chain cover and replenish with oil as described on page 14.

A rubber button is fitted to the end of the adjusting screw to prevent the transmission of chain noise to the chaincase. This is held against the chaincase and bouncing is prevented by a hairpin spring.

The rear chain is adjusted by means of cam-shaped adjusters on the rear wheel spindle. These bear against fixed pegs in the fork ends. Any adjustment is made by slackening the spindle nuts and brake anchor nut and turning the cam plates until the required chain tension is achieved. Test this by spinning the wheel and feeling the up and down play as described for the front chain. In this case, however, allow $\frac{1}{2}$ in. movement. Move each cam plate the same number of notches to maintain correct wheel alignment. If the wheels can be lined up only by having one adjuster engaging a different

notch from the other, check the chain line and if this is correct all will be well, but if wheel alignment and chain alignment cannot be achieved together, the probability is that the frame has been bent as the result of some mishap.

For the “Meteor Minor” adjustment is similar but the two screws “A” (Fig. 22) anchoring the rear chaincase to the swinging arm just behind the flexible gaiters must first be slackened. Tighten them after the adjustment has been made.

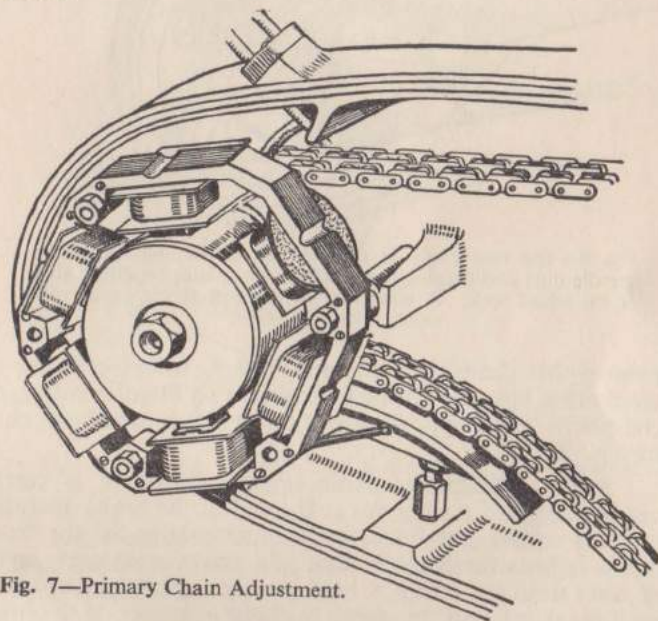

Fig. 7—Primary Chain Adjustment.

- 18 **Rear Chaincase Removal.** By removing the rear end of the chaincase, held by three screws, by taking out the two screws holding the upper and lower halves of the case to the wheel hub, and the two securing them to the swinging arm, the rear chaincases may be removed.

After adjusting the rear chain, the rear brake operating rod may also require adjustment. Should it be necessary to

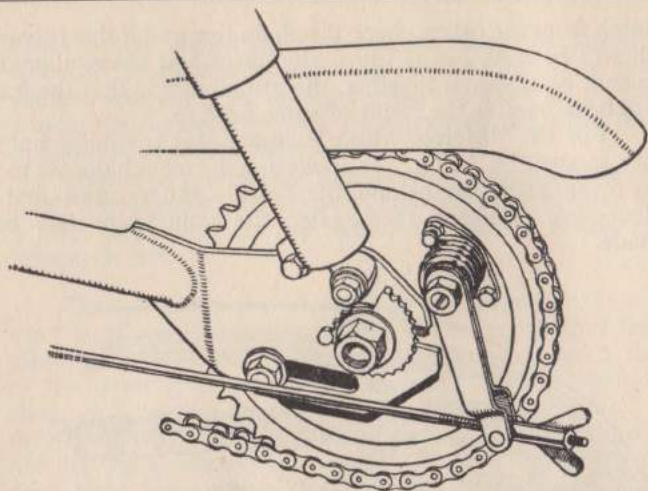

Fig. 8—The rear chain is adjusted by slackening the wheel spindle nuts and turning the notched cam plates on either side of the wheel fork. A wing nut on the end of the brake rod adjusts the rear brake.

remove this chain, it is important that, when replacing the connecting link, the spring fastening is so fitted that the spilt end points in the opposite direction to that in which the chain travels.

- 19 Brake Adjustment.** Rear brake adjustment is carried out by means of a wing nut at the end of the brake operating rod. A milled nut beneath the outer casing of the brake cables adjusts the front brakes. In either case, screw up the adjuster until the brake is hard on, then gently slacken back until the wheel will spin freely without any trace of the brake shoes rubbing the drums. Adjust each side of the brake equally so that the compensating device at the handlebar lever is square with the bar when the brake is applied. The brake arms, splined to the cam spindles, may be removed and turned to engage the splines in a different position. In this way a further means of brake adjustment is possible.

Both wheels have deep groove journal ball races which require no adjustment.

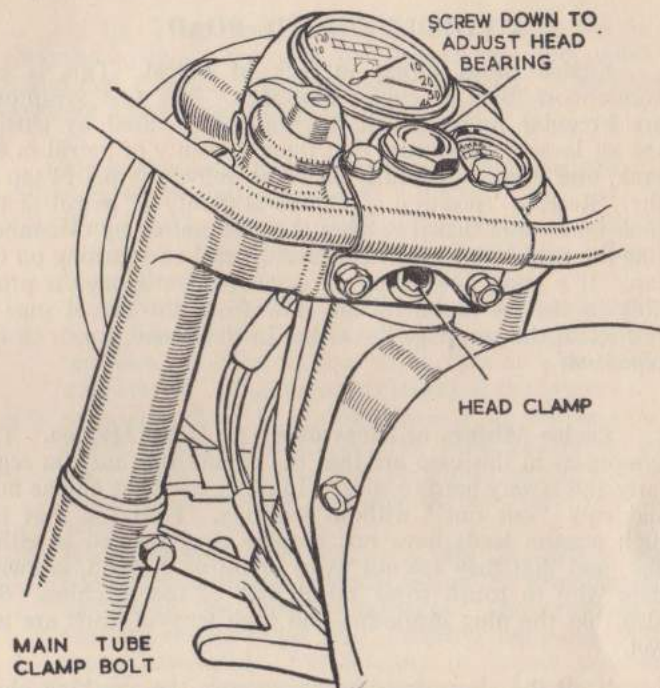

Fig. 9—Showing the positions of the clamp bolts securing the steering stem and fork tubes.

- 20 Steering Head Adjustment.** Undo the head clamp; this is in the form of a wedge bolt and is unscrewed by means of a key in the internal hexagon. Unscrew, also, the two clamp bolts securing the main fork tubes. Tighten down the central large hexagon above the handlebar clip until bearing play has disappeared. Do this with the weight taken off the wheel. When adjustment is correct, tighten up the clamps.

What, apparently, is excessive engine vibration may sometimes be caused by a loose steering head.

Other adjustments relating to the engine are dealt with in the section "Overhauling the Engine" commencing on page 26.

TROUBLE ON THE ROAD

21 Engine Stops owing to lack of Petrol. This is the commonest form of engine stoppage. The first symptoms are irregular firing, which is temporarily cured by closing the air lever. Make sure that there is plenty of petrol in the tank, and if necessary turn the lever above the petrol tap to the "Reserve" position. If there is plenty of petrol in the tank make sure that it reaches the carburettor by disconnecting the petrol pipe at the carburettor end and turning on the tap. If a good flow of petrol occurs, the stoppage is probably in the jet itself. If the flow from the petrol pipe is restricted, the stoppage lies either in the petrol tap or in the pipe itself.

22 Engine Misfires or Stops owing to faulty Ignition. The symptoms in this case are that the engine will not run regularly and is very hard to start. In other cases the engine may suddenly "cut out" without warning. First see that the high tension leads have not become disconnected at either end, and that they are not worn or burnt through, allowing bare wire to touch some metal part of the machine. See also that the plug insulators and high tension leads are not wet.

If all the above is in order, remove the sparking plugs and place each one with the body touching the engine cylinder, but with the terminal clear of the machine and connected to the high tension lead. Turn the engine round by the kick-starter. If a good spark is obtained at the plug points, the ignition is in order and the trouble lies elsewhere. If no spark, or a very weak spark, is obtained, remove the plug and hold the end of the high-tension wire about $\frac{1}{8}$ in. from a metal part of the machine and rotate the engine. If a spark is obtained from the wire, the fault lies with the sparking plug. If this is oily or sooty it can be taken apart and cleaned, but if the points are red and burnt the plug has been too hot and a new one should be fitted, of the type recommended in paragraph 40. The gap between the plug points should be .018 in. to .025 in. (.45 mm. to .65 mm.).

If the plugs are satisfactory, the trouble lies in the ignition system. See that the contact breaker points are clean and that they open and close properly. These should open to a gap of .012 in. (.30 mm.).

23 Other Causes of Engine Stoppage. Other possible causes of an engine stoppage are:—

(1) **Water in Carburettor.** The symptoms are usually intermittent misfiring and banging in the silencer following a heavy rainstorm.

The remedy is to clean out the float chamber and jets.

(2) **No Clearance at Tappets.** This is apparent by an entire lack of compression when turning over with the kick-starter. The remedy is to adjust the tappets.

(3) **Sticking Valve.** In this case there is no compression and excessive tappet clearance, the valve remaining partly open. The valve may free itself on cooling, but sometimes it is necessary to dismantle the engine to free the valve.

(4) **Broken Valve.** This trouble is very rare and is usually caused by consistent over-driving of the machine and by neglect of the tappet clearances. The symptoms are that the engine "cuts out" suddenly and stops with no tappet clearance. Furthermore, it is not possible to obtain any clearance at the tappets. A valve breakage on an O.H.V. engine is likely to have very serious consequences.

(5) **Seized Piston.** This is caused by over-driving a new machine before the engine is properly "run in." The symptoms are loss of power and a tendency to "pink" followed by the engine locking up solid. An aluminium piston will always free itself if allowed to cool. If the clutch was withdrawn and the throttle closed before the final seizure the consequences may not be serious, but the cylinders and pistons should be examined as soon as possible by a competent mechanic to have any score marks removed. A seizure may also occur through running with insufficient oil, in which case the consequences will be far more serious.

24 Clutch Trouble. A slipping clutch may be caused by lack of clearance in the control (see page 19).

A dragging clutch is caused by too much slack in the control wire. New clutches sometimes tend to drag until the inserts have bedded down level.

OVERHAULING THE ENGINE

25 Decarbonising. The removal of carbon deposit from cylinder heads and pistons will become necessary at intervals. Decarbonising should be done after the first 2,000—2,500 miles and, subsequently, approximately every 5,000 miles.

26 Cylinder Head Removal. Remove the petrol tank by detaching the petrol pipe and removing the bolt which secures the tank to the frame at the front. It may help if the front saddle anchorage or dual seat are removed. Take away the cylinder head stay, detach the external oil pipes,

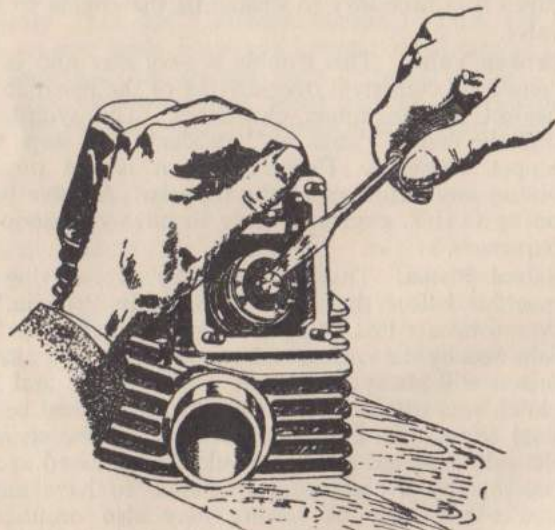

Fig. 10—Removing Steel Thimbles or End Caps when removing valves.

carburettor, sparking plugs, induction pipe, and remove the exhaust pipes and silencers.

Turn the engine until both valves are closed on the head to be removed. Remove the five sleeve nuts securing the head, after which it may be lifted.

27 Removal of Valves ("Super Meteor" and "Meteor Minor"). Remove the rocker covers, each held by four nuts, swing the rocker clear of the valve and lift or prise away the hardened steel thimbles or end caps. If these have stuck, they can be removed by means of a screwdriver (Fig. 10). Using a suitable valve spring compressing tool (Fig. 11), compress the valve springs and remove the split conical collars from the end of the valve stem. Slacken back the compressor and release the spring; withdraw the valve and place its springs, top spring collar (and bottom collar if it is loose) and split conical collars together in order that they may be assembled with the valve from which they were removed. Deal similarly with the other valve in the head.

Removal of Valves ("Constellation"). No steel thimbles are fitted to the ends of the valve stems as in previous models, otherwise the above instructions for valve removal may be followed.

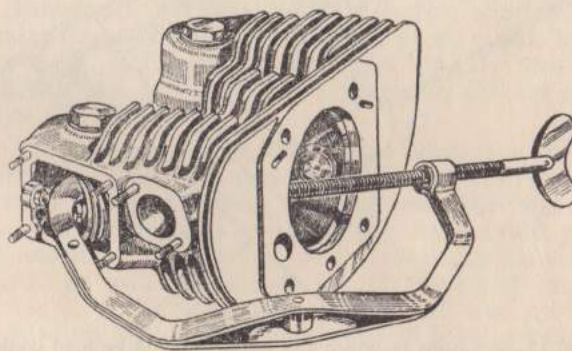

Fig. 11.—Using a suitable Valve Spring Compressing Tool.

28 Removing the Carbon. Scrape away all carbon from valve heads and beneath the heads, being very careful not to cause any damage to the valve faces. Bearing in mind that you are dealing with aluminium, remove carbon also from the cylinder head and valve ports. Scrape gently and avoid scoring the combustion chamber or damaging the valve seats which are of austenitic iron shrunk into the head. Be careful while performing this work not to injure the joint face which beds down on to the head gasket.

Do not, in any circumstances, use potash or caustic soda for carbon removal from these aluminium alloy heads.

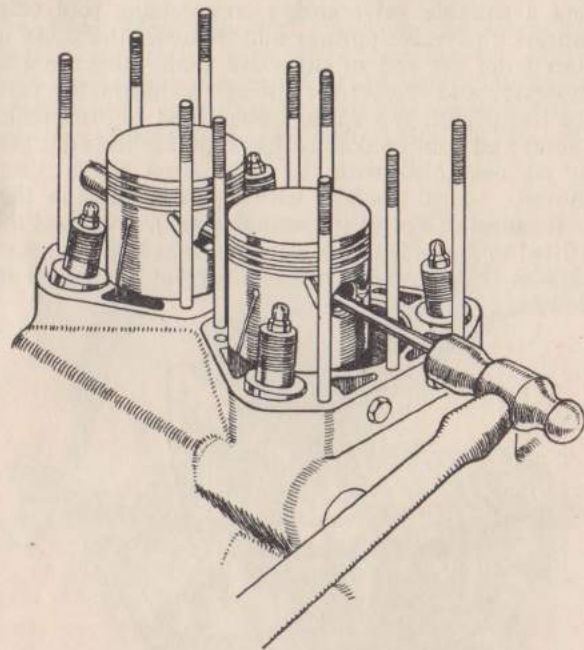

Fig. 12—Positions in which the pistons should be held while the far gudgeon pin is being tapped out by a rod passed through the nearer piston.

29 Piston Removal. It is possible to scrape the piston tops clear of carbon without removing the cylinder barrels, but, since this latter is a very easy task and it may be just as well to examine the state of the piston rings, the cylinders may be lifted clear. With the tang of a file remove the two outer circlips retaining the gudgeon pins. Rotating the engine very gently, bring the pistons into such a position that the gudgeon pins, when being withdrawn, will clear the long cylinder studs. Using a rod about $\frac{1}{2}$ in. in diameter, insert this rod through one gudgeon pin and push the other pin out of its piston. Having lifted the first piston away, the other one may readily be removed. Mark them so that each goes back into the same cylinder and the same way round.

In the case of broken or gummed-up piston rings, they should be removed, the grooves cleaned out and new rings fitted or the old ones cleaned carefully and refitted. For cleaning the grooves, a piece of a discarded ring thrust into a wooden handle and filed to a chisel point is a useful tool.

While the cylinders and pistons are not in position on the engine, cover the crankcase with a clean cloth to prevent the ingress of dust and dirt of all kinds. Do not, of course, attempt to scrape the carbon from the pistons when the mouths of the crankcase are open.

30 Grinding-in Valves. Wipe the valve faces clean and examine them carefully. If they are at all pitted, have the faces re-cut. Pay similar attention to the valve seats in the head; excessive grinding will form a pocket and the gas flow will be restricted.

To grind in a valve, smear the seatings with a little grinding-in compound, place a light, short coil spring over the valve stem and beneath the head, insert the valve into its appropriate guide, press it on to the seat, using a valve grinding tool, and with a backwards and forwards rotary motion, grind it on to its seat. Frequently lift the valve and change its position so that you achieve an even and true seating. If you have no light spring, the lifting will have to be done by hand. Continue grinding until a bright ring is obtained on both valve and seating.

If the valve or seats are very badly pitted and will not form good faces with a reasonable amount of grinding, the parts should be returned to the Works for new seats to be cut. Excessive grinding forms a pocket which restricts the flow of the gases.

Do not interchange the inlet and exhaust valves as they are of different materials as well as being different in diameter.

- 31 **Re-assembling the Engine after Decarbonising.** Before building up the engine again, see that all parts are scrupulously clean and, having cleaned them, place them conveniently to hand on a trestle or working platform covered with a clean sheet of brown paper.

It might be mentioned here, that it is recommended that new cylinder base and head gaskets be fitted. Two paper gaskets are fitted to the base of each cylinder.

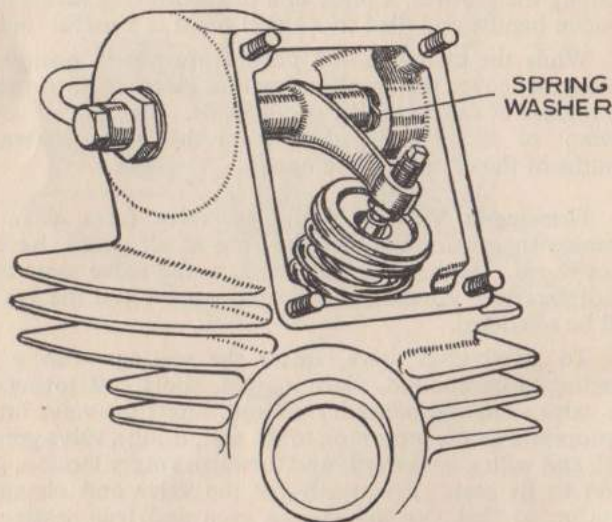

Fig. 13—The tappet adjuster is screwed into the rocker and retained by a locknut beneath the rocker. Note the position of the spring washer behind the rocker pivot.

Smear clean oil over the pistons, having replaced the rings if these have been removed, space the ring gaps, lower the piston over the connecting rod and insert the gudgeon pin from the outer side; fit the circlip and then fit the second piston in a similar manner.

Oil the cylinder bores and lower each barrel over the pistons and seat them gently on their gaskets. Drop the push rods down their tunnels on to the tappet heads, shallow cups upwards. The valves must next be fitted into the heads by a reversal of the process of removing them. Apply a thin coat of jointing compound to the cylinder head gaskets, which are of solid copper and see that the dowels are in position.

Ease the heads over the cylinder studs, taking care that the push rods engage the rockers in the right manner. When they are safely in position, screw on the sleeve nuts and commence to tighten them down. Tighten all nuts progressively and diagonally from one side to the other in order that no distortion shall take place and that a true joint shall be made. Just before the nuts are tight, fit the induction pipe and gaskets and finally tighten the cylinder head nuts.

- 32 ***Tappet Adjustment ("Super Meteor" and "Meteor Minor").** Before replacing the rocker covers, check the tappet adjustment. Always adjust the tappets when the engine is cold and make sure that the tappets are clear of the silencing ramps on the cams. This is done by turning the engine until the other valve in the same head is open. Make the adjustment by releasing the locknut beneath the rocker head and turning the adjusting screw in the desired direction. Set the inlet so that the rocker is just held without it being possible to move it end-wise by hand. Set the exhaust so that the rocker **will** just move end-wise when pushed by hand. Refit rocker covers and gaskets.

***Tappet Adjustment ("Constellation").** When adjusting the tappets, make certain that the appropriate valve is on

* For continuous high speed running (as in racing), the following tappet clearances are recommended for the "Constellation" and "Super Meteor," with the engine cold :—Inlet nil ; Exhaust '005.

its seat by turning the engine slowly until the other valve in the same head is fully open. For normal running conditions make the adjustment in the manner already described for the “Super Meteor” and “Meteor Minor.”

- 33** **Completing Assembly after Decarbonising.** All that now remains to be done is to refit the external oil pipes, making sure that they are clear and that the oil passages, too, are free of dirt; re-connect the cylinder head steady to the engine and frame, refit the carburettor and the exhaust pipes, then remount the petrol tank and connect up the petrol pipe and the plug leads.

Run the engine for a brief period and when excessive smoking at the exhaust has ceased, stop the engine and go over all the cylinder head nuts, including those between the cylinders, oil pipe unions, carburettor securing nuts and exhaust pipe nuts. Do this again after the engine has had a good run and reached a high temperature. After allowing to cool, check the tappet clearances.

- 34** **Removal of the Engine from the Frame.**
Disconnect the battery leads.
Remove the dual seat and petrol tank.
Remove the engine steady.
Remove the tool box cover and slide the flexible connection to the air cleaner off the induction pipe.
Remove the exhaust pipe.
Disconnect the electric horn leads.
Disconnect the alternator leads from rectifier and swing the rectifier clear.
Disconnect the distributor lead (where fitted).
Remove the slides from the carburettor.
Remove the rear chain.
Disconnect the clutch control.
Remove the foot rest bar.
Remove the bottom rear engine bolt.
Support the engine on a suitable box or wood block.
Raise the centre stand and remove the spring.
Loosen the bottom gearbox nuts and swing the lower engine plates down.
Remove the front engine plates, horn and prop stand.
Lift the engine out of the frame.

- 35** **Fitting the Alternator.** The alternator consists of two parts, the stator and the rotor. The stator is mounted on the back half of the primary chaincase, being held in position by three studs and distance pieces. The rotor, which contains the permanent magnet is mounted on the end of the crankshaft and is secured by a nut and located by a key.

The radial air gap between the rotor and the poles of the stator should be .020 in. in all positions and care must be taken when re-fitting to see that it is not less than .010 in. at any point.

Fit the rotor first, making sure that it is located concentrically on the end of the crankshaft. Attention must be given to the seating of the key because a badly-fitting key may cause the rotor to run unevenly. The nut holding the rotor in position is secured by a tab washer.

Having fitted the rotor, place the three distance collars over the three studs in the primary chaincase and put the stator in position with the coil connections facing outwards.

Replace the nuts and shakeproof washers only finger-tight and insert six strips (preferably of non-magnetic material) .015 in. thick and about $\frac{1}{8}$ in. wide between the rotor and each pole piece.

Tighten the stator nuts and withdraw the strips.

Check the air gap with narrow feelers and, if less than .010 in. at any point, remove the stator and file or grind the pole piece carefully until the correct gap is obtained.

- 36** **Removal of Engine and Clutch Sprockets.** To remove the primary chaincase cover, unscrew the central screw securing it.

The primary chain is endless so that it is necessary to remove both the engine and clutch sprockets simultaneously.

Remove the alternator stator by undoing three fixing screws and remove the chain tensioner pads.

Remove the central hexagon nut securing the alternator rotor, which can then be drawn off, taking care not to lose the key.

Unscrew the engine sprocket nut (there is a Special Tool No. 4877). The engine sprocket is mounted on splines and can then be removed with the clutch sprocket.

To remove the clutch sprocket unscrew the three clutch spring pins, then lift away the spring cap, springs and distance pieces, clutch front plate, centre retaining ring and the assembly of driving and driven clutch plates. The clutch sprocket can then be withdrawn from the centre after removal of the large circlip which secures it.

When replacing the engine sprocket, take care that the felt washer is not nipped behind the sprocket. This would make the engine very stiff to turn over and would damage the washer and allow leakage from the crankcase.

Remove the clutch hub by holding the clutch, preferably by Special Tool E4871 and unscrewing the centre nut with a box spanner. The hub can then be withdrawn with Extractor E5414. The back half of the chain case can be lifted off after removal of the three screws securing it to the crankcase.

37 **Ignition System.** Current models of the "Super Meteor" and "Meteor Minor" have ignition and lighting by an alternator, coil and distributor.

The alternator is housed in the primary chain case, the rotor being held to the driving shaft by a single nut with a lock washer. The stator is held to the back of the chain case by three nuts.

On the engine shaft there is an adaptor to take the rotor and it is possible to fit this adaptor in either of two positions, making a difference of half a revolution.

Timing the Ignition. Fit the stator with the leads from it on the inside, facing the back of the chain case. Turn the engine until the left-hand piston is at top dead centre of the firing stroke. Put the rotor adaptor on the shaft with the keyway in the 12 o'clock position. Fit the rotor. With the parts in these positions easy emergency starting will be achieved.

Slacken the clamp bolt, which holds the distributor to the housing at the back of the timing case. Turn the distributor body until the points are just breaking with the piston $\frac{1}{8}$ in. before top dead centre on the compression stroke. The automatic ignition control gives a fully retarded ignition point when at rest. With the ignition points closed, the ammeter will show a discharge and the point at which they open will be revealed by the ammeter needle returning to zero. This is a more accurate method of determining the breaking of the contact points than using a feeler or piece of paper between the points.

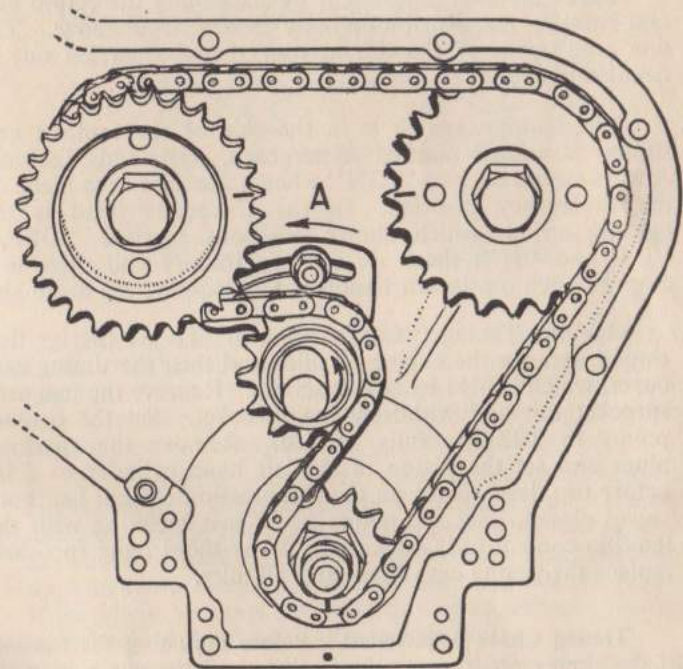

Fig. 14—Timing marks and direction in which eccentric and locking plate must be moved in order to adjust the timing chain.

In the event of a general overhaul where complete dismantling has taken place, clamp the distributor housing with the name on the cover roughly horizontal.

Turn the engine until the left-hand piston is $\frac{1}{8}$ in. before top dead centre on the compression stroke, loosen the cam and turn it until the contacts are just opening with the rotor arm, if replaced, pointing towards the lead to the left-hand sparking plug. Give the cam a sharp tap endways to secure it on the spindle and lock it tightly with the centre fixing screw.

Make the final adjustment by slackening the clamp bolt and rotating the distributor body as described above. The fine adjustment of the timing may then be carried out as detailed above.

The ignition switch is in the side of the toolbox and shows positions marked Emergency, Off and Ignition. Always switch back to 'IGN' when a start has been made on the Emergency position. In the Casquette head is the lighting switch which shows positions marked 'OFF,' 'L,' and 'H'; these are self explanatory and there is a dipper switch on the left handlebar for dipping the headlight.

Ignition Timing ("Constellation"). To set the ignition timing, remove the engine oil filler and then the timing case cover, which is held by twelve screws. Remove the magneto sprocket nut and withdraw the sprocket. Set the contact points to .012 in., fully opened. Remove the sparking plugs and set the piston in the left hand cylinder to $\frac{3}{8}$ in. before top dead centre on the compression stroke; i.e., both valves closed. Set the points to be just breaking with the ignition control fully advanced. Refix the driving sprocket, replace the timing case cover and oil filler.

- 38 **Timing Chain Adjustment.** Before adjusting the tension of the timing chain, turn the engine until the chain is in its tightest position, checking the chain between all sprockets. Adjust the tension so that there is $\frac{1}{4}$ in. movement of the chain.

The tension of the timing chain is altered by moving the quadrant after slackening the nut which secures it. This rotates the eccentric spindle on which the chain tensioner jockey sprocket is mounted. Tightening of the chain is effected by moving the quadrant to the left.

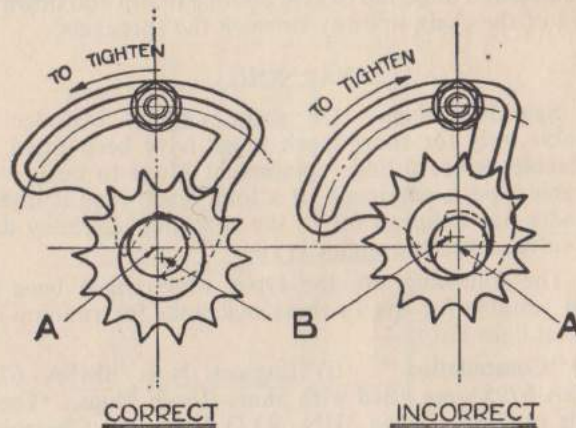

Fig. 15—Timing chain adjustment.

It is imperative that the quadrant is fitted the right way round and that the eccentric spindle is fitted correctly in the quadrant fork. If the chain tightens when the quadrant is moved to the right, the tensioner has been wrongly assembled and may cause damage to the quadrant (see Fig. 15).

In making the adjustment, care must be taken to see that any backlash in the quadrant is taken up in the "tightening" direction, i.e. do not make the chain too tight and then move the quadrant back slightly, but tighten the chain progressively until the correct tension is obtained and then lock the quadrant. If the chain becomes too tight during adjustment, slacken it right back and make the adjustment again.

If the chain is too slack, it may give rise to a loud noise which can be mistaken for a faulty bearing. If such a noise is heard, therefore, first check the adjustment of the timing chain.

- 39 **Magneto Chain Adjustment ("Constellation").** Some adjustment may be obtained by removing the timing case cover and undoing the three bolts which hold the magneto and its adaptor plate to the timing case. The slots in the latter are slightly elongated and the magneto may be slid in the desired direction to give about $\frac{3}{8}$ in. up and down movement of the chain midway between the sprockets.

WARNING

- 40 **Sparking Plugs.** On some engines cylinder heads suitable only for short reach plugs have been fitted. It is advisable before fitting replacement plugs to ensure that a suitable type is obtained. If a long reach plug is fitted to a cylinder not designed for it, the sparking plug may damage the valves when the engine is run.

The following are the types which have been found most suitable for use in these machines for running-in and normal light duty:—

"Constellation." (i) Engines Nos. SMSA 6751 to SMSA 6795 were fitted with Short Reach Plugs. The types to be used are Lodge 3HN, KLG F100 and Champion L5 (formerly L11S).

(ii) Engines Nos. SMSA 6796 onwards take Long Reach Plugs, viz: Lodge 2HLN, KLG FE75, or Champion N5 (formerly NA8). For high speed running over long distances, use Lodge 3HLN, KLG FE100 or Champion N3 (formerly NA10).

"Super Meteor." (i) Engines Nos. up to SMQA 4687 (Short Reach): Lodge H14, KLG F70 or Champion L7 (formerly L10S).

(ii) Engines Nos. SMQA. 4688 onwards (Long Reach): Lodge HLN, KLG FE70, or Champion N5 (formerly NA8).

"Meteor Minor." (i) Engines SMCA 7001 to SMCA 7027 (Short Reach): Lodge H14, KLG F70 or Champion L7 (formerly L10S).

(ii) Engines SMCA 7028 onwards (Long Reach): Lodge HLN, KLG FE70 or Champion N5 (formerly NA8).

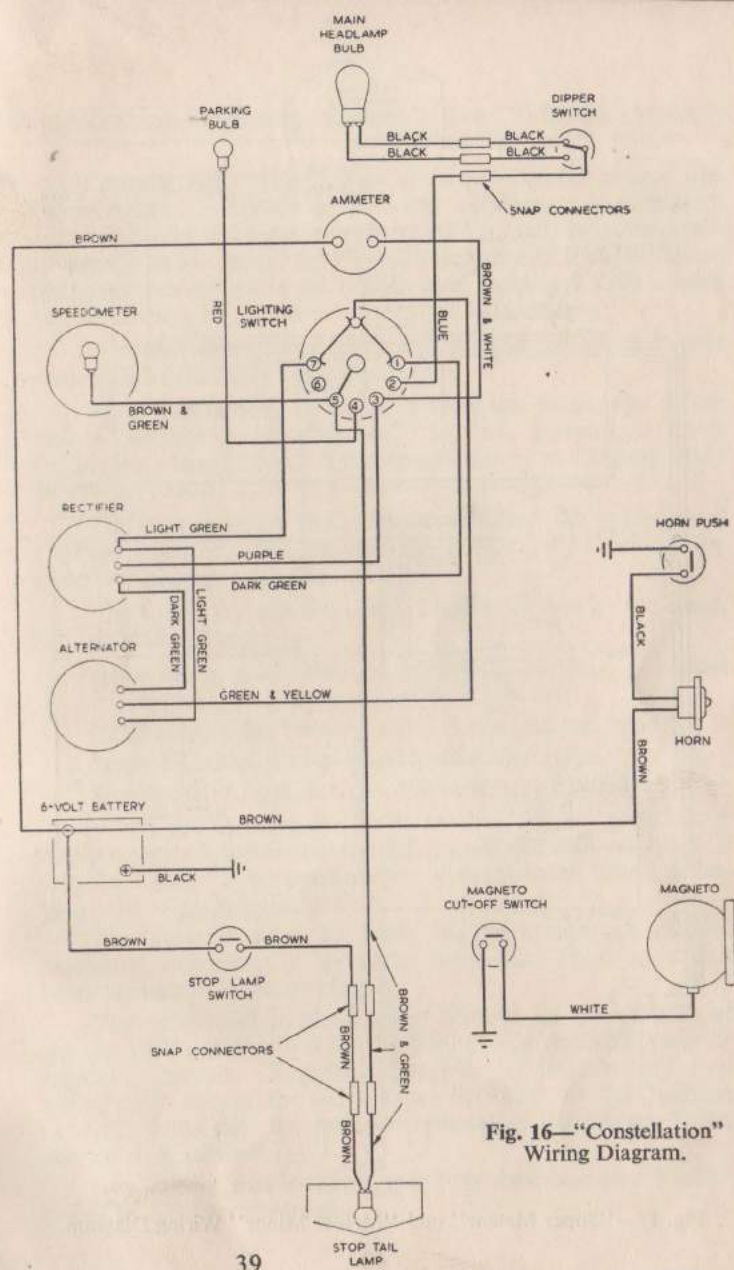

Fig. 16—"Constellation" Wiring Diagram.

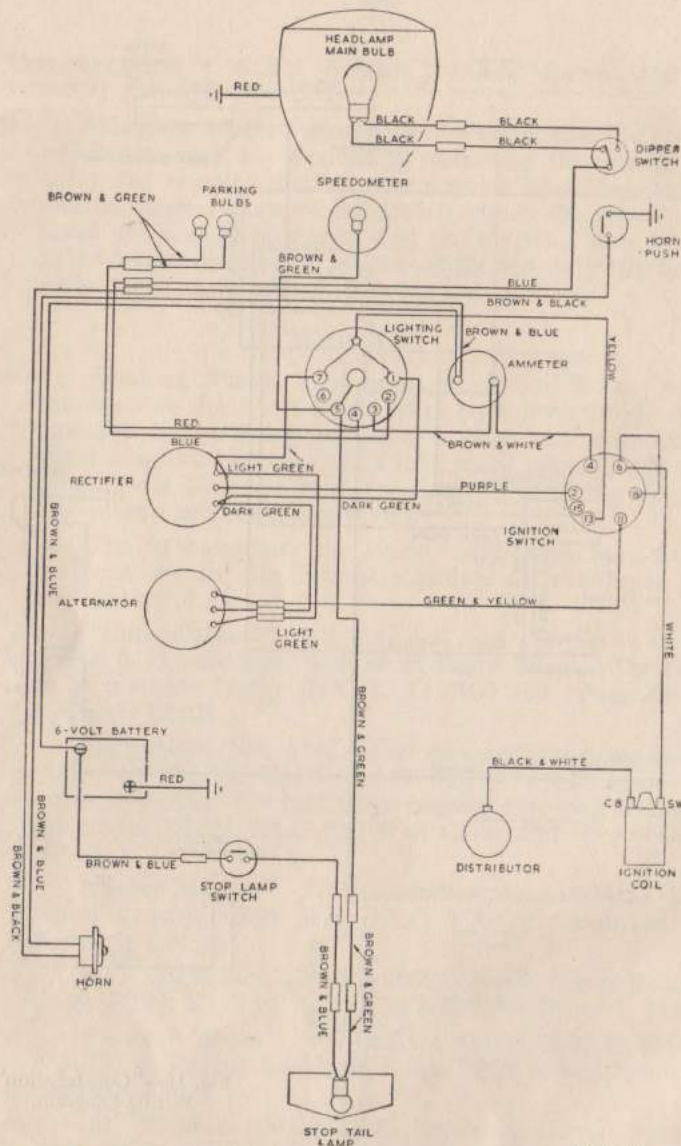

Fig. 17—"Super Meteor" and "Meteor Minor" Wiring Diagram.

"CONSTELLATION,"—"SUPER METEOR" AND "METEOR MINOR"

41 **Lighting Set.** The battery on a new model is sent out "dry-charged." It must be filled with sulphuric acid of density 1.270 (1.210 in temperatures above 90°F.) made by adding one volume of acid density 1.835 to 2.9 volumes of distilled water (4.0 volumes of water to obtain acid density 1.210). Acid should always be added to water, not vice-versa.

It is important that each cell should be filled in one operation to the top of the separators.

Allow the battery to stand at least one hour after filling before putting it into service. If time permits, a short freshening charge of not more than 4 hours at 1.0 amp. may be given.

The alternator on the machine will keep the battery well charged provided the motorcycle is not left standing for excessive periods with the lights on.

The following are the correct bulbs for use in the head, tail, and other lamps:—

Head lamp, main bulb, 6 volt—30×24 watt, pre-focus type.

Head lamp pilot bulbs, 6 volt—3 watt, m.b.c. type.

Stop-tail lamp, 6 volt—6×18 watt s.b.c. type.

Speedometer light, 6 volt—1.8 watt, m.b.c. type.

When the lighting switch is in the "high" position, a finger-operated switch on the left handlebar can be used to dip the light. The speedometer is illuminated when either the main or pilot bulbs are on.

The various wires or leads in the system should be examined occasionally to make sure that they have not become disconnected or chafed.

The acid level in the battery should be maintained at the top of the separators by the addition of distilled water at regular intervals. Regular attention to the battery and wiring will ensure the satisfactory working of the lighting system. **Note that the positive terminal of the battery is the one which is earthed.**

The lighting and ignition set is fully described in a booklet issued by the manufacturers.

42 **Carburettor ("Super Meteor" and "Meteor Minor").**
This is a simple instrument having integral float and mixing chambers. Access to the float is gained by removing the three screws holding the float chamber cover. Between the latter and the body is a gasket which must not be damaged. The nylon float needle seats in the feed member which is screwed into the carburettor and is provided with a fine gauze filter.

Below the instrument is the jet holder screwed into the jet block. The latter should never need removal. Into the bottom of the jet holder the main jet is screwed and may be reached simply by removing the cap and nut below it. The jet holder will have to be removed to reach the needle jet which is screwed into the top of the jet holder. A smaller cap nut covers the pilot jet which may be unscrewed with a screw-driver for cleaning purposes. At right angles to this jet is the spring-loaded pilot air screw by means of which the slow running may be adjusted. A similar, rather larger screw forms a throttle stop by means of which the throttle may be set so that the engine ticks over when the twist grip is fully home. The throttle slide carries a taper needle, raising or lowering which enriches or weakens the fuel mixture. An air slide operated by a handlebar lever is used, primarily for starting from cold.

Beyond keeping the feed pipe gauze clean, the float needle seating and all jet orifices clear and the possible adjusting of the slow running, the carburettor is not likely to need attention. Do not fit a smaller main jet in the attempt to improve fuel consumption.

The following are the correct carburettor settings :—

Main Jet **240** ("Super Meteor"); **250** ("Meteor Minor").

Needle Jet **106**.

Throttle Valve, **376/3½**.

Needle clip in No. **3** groove ("Super Meteor");
No. **2** ("Meteor Minor").

Pilot Jet **30**.

Carburettor ("Constellation"). This is an Amal type 10TT, having a choke diameter of $1\frac{3}{16}$ in. It is flange mounted on a Y-shaped induction stub attached to the cylinder heads. The float chamber is attached to the mixing chamber body by a large hexagon which also forms the jet holder. Beneath this is a jet holder plug screw which must be removed to gain access to the jet. On the side of the mixing chamber is formed the mixture control boss. Air is fed into this through a long slot and is controlled by a slide operated by a cable from a lever on the handlebar. An adjuster and a locknut are provided for this cable. Alongside the mixture control boss is a milled screw with a spring retaining catch and this is the pilot needle for adjusting the slow running.

The twist grip operates the throttle slide and the needle controlling the needle jet. The cable for this control also has an adjuster and locknut. Alongside this adjuster is a small, square-headed screw which adjusts the lock plunger securing the screwed ring encircling the mixing chamber cap. Hexagon-headed screws secure the float chamber lid, a tickler for flooding the carburettor is provided, and the nut holding the twin banjo to the float chamber has provision for a locking wire.

The following are the correct carburettor settings:—

Main jet 480

Needle jet 109

Throttle valve ... No. 5

Needle clip in third groove from top.

Full particulars of the carburettor are given in a booklet issued by the makers.

43 **Air Cleaner.** This contains a dry felt element which must **not** be oiled. It is cleaned by brushing and blowing with compressed air.

TRANSMISSION

44 Enfield Four-Speed Gear. This gearbox is very simple in operation, and provided it is kept well lubricated will give long and trouble-free service. A special feature is that the gears are controlled by a single striking fork so that it is quite impossible to engage two gears at once no matter how much wear has taken place.

The foot control lever is mounted directly on the box and consequently the gear cannot get out of adjustment. It may, however, be found that the gear control lever is too close to, or too far from, the footrest. In this case, slacken the pin securing the lever to the operating mechanism on the box, remove the lever and replace it one serration higher or lower as required.

On these machines a special neutral finding lever is fitted. This enables neutral to be found immediately from second, third or top gears. Forward and downward travel of this lever is limited by a stop sleeve. If the lever fails to locate neutral, loosen the hexagon-headed screw which secures the sleeve, and turn the latter. The sleeve is eccentric so that rotating it adjusts the position of the neutral finder at the end of its travel.

45 Clutch. The clutch is of the five plate type ("Super Meteor") and four plate type ("Meteor Minor" and "Constellation"). If clutch slip occurs, first make sure that there is the requisite amount of slack in the control wire, see page 26.

If this is in order, the clutch plates should be examined. To do this remove the front half of the primary chain case and unscrew the three pins near the centre of the clutch. The springs and plates may now be lifted away. If the inserts are worn flush with the metal or are burnt, they should be renewed. If the machine has been run for some time with a slipping clutch, new springs as well as new inserts may be required.

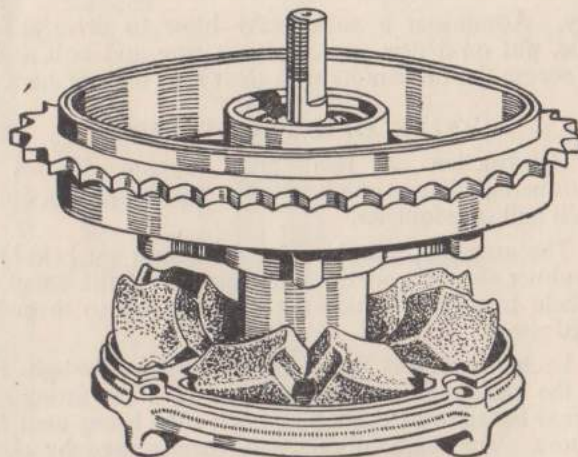

Fig. 18—In assembling the cush drive hub, set the rubbers against each other as shown to provide a lead for the vanes.

46 Patent Cush Drive Rear Hub. This hub has a marked effect on the running of the machine, absorbing all engine shocks and preventing any snatching of the driving chain, consequently minimising wear on the rear tyre. The drum on the driving side of the rear hub is provided with three metal vanes, and the inside of the driving sprocket has three similar vanes. On each side of the vanes in the hub is placed a block of solid rubber, and the vanes on the inside of the driving sprocket fit between these blocks. When in position there is a block of rubber and a metal vane alternately.

This cush drive hub is so simple that the only parts likely to wear are the rubber blocks and the lock ring, which however, will last a considerable time.

To renew rubbers, or refit them if the cush drive has been dismantled, place the rubbers in the hub leaning at an angle against each other as shown in the illustration in Fig. 18. Insert the opposing vanes between them, having first coated the vanes lightly with soap—**not oil**—to ease their

entry. Administer a good hefty blow to drive the vanes home, put on a new sprocket lock ring and bolt assembly, and secure the three bolts with their nuts and washers.

TELESCOPIC FRONT FORK

- 47 **Construction.** A light alloy casting, known as a "Casquette," houses the headlamp, parking lamps, ammeter, switch and speedometer.

The ammeter, switch and small lamps are held in place by rubber sleeves and the lamp glasses of the small lamps are held in rubbers which are tightened on to them by the plated rims.

Each fork leg is thrust upwards into this light casting and the main tubes are screwed into it, a key fitting into an internal hexagon at the top of each tube being used for the purpose. The main tubes are further secured by clamping bolts at the fork crown, and a wedge bolt holds the steering head stem at the upper end. This latter is accessible from behind the handlebar mounting.

Between the top tube covers—which are part of the "Casquette" and the fork crown—are rubber washers which allow for any variation brought about by adjustment of the head bearings.

The bottom or sliding tube encases the lower part of the main tube and has, screwed to its upper end, an oil seal housing which, besides containing the oil seal, retains the top bush in the sliding tube. Screwed into the base of the main tube is a valve port which also secures the bottom bush.

In this fork a two-phase spring is used, and it abuts against spring guides at top and bottom.

Thrusting upwards from the base of the sliding tube is a hollow spring stud which passes through the bottom valve port and has the bottom spring guide attached to its upper end by a nut. This spring guide has a ring of ports similar to those in the bottom valve port and each ring of ports is controlled by a valve plate or flap valve.

As the spring is compressed, both valve ports remain open, oil passes freely through them and no damping is

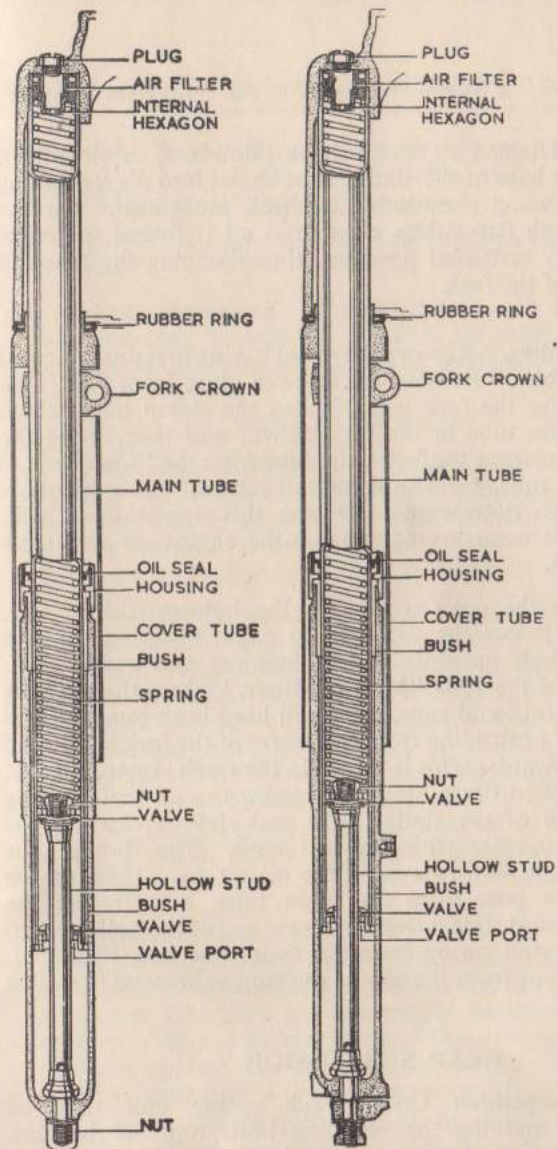

Fig. 19—Telescopic front fork ("Constellation" and "Super Meteor")

Fig. 20—Front Fork (1959 "Meteor Minor")

Fig. 21—Bottom section of 1958 "Meteor Minor" front fork, which is otherwise similar to the fork on the 1959 model.

achieved. Under very severe shocks, however, an oil control collar at the base of the sliding tube comes into play, trapping oil, and forming a cushion to check movement. On the rebound, both flap valves close, and oil is forced to return through very restricted passages, thus damping the rebound movement of the fork.

- 48 **Dismantling.** Remove the wheel having first disconnected the brake cables. Remove the screwed plugs from the "Casquette" above the fork legs, slacken the clamp bolts which hold the main tube in the fork crown; and then, using the special key, unscrew the fork main tube from the "Casquette." The bottom tube, main tube and all internal parts may now be withdrawn downwards. During this operation, it will, of course, be necessary to support the engine on a suitable block or box.

Remove the nut from below the bottom sliding tube. With a tin below the fork leg to catch escaping oil, tap the hollow bolt upwards with a hammer and a soft drift. In the case of the 1958 "Meteor Minor," where the wheel is held by two fork end caps, these will have been removed and the stud now protruding from the centre of the fork leg should be tapped upwards. This is shown in the small sketch, Fig. 21. Allow the oil to drain away. Unscrew the oil seal housing from the top of the sliding tube and slide it clear of the main tube together with the top bush. The sliding tube can now be slid downwards off the main tube. Unscrew the bottom valve port from the main tube, thus freeing the bottom bush and slide it over the lower end of the hollow stud. Remove the stud spring from the main tube and, if desired, unscrew the nut from the top of the stud to remove the valve port.

REAR SUSPENSION

- 49 **Rear Suspension Units.** Each spring unit may be removed by undoing the retaining bolts top and bottom. Rubber bushes at either end may be pressed out and new ones fitted in case of wear, and the springs also may be

renewed. To do this, push the cover down—preferably with the aid of a press—lift out the collar at the top, lift up the outer spring cover and then the spring.

Heavier springs are available for machines used with sidecars.

Rear Suspension ("Constellation"). Each rear suspension unit may be adjusted for load by turning the knurled ring which is just above the sliding member.

MISCELLANEOUS

- 50 **Removing Camshafts ("Constellation").** When employing the machine for special purposes involving requirements differing from the normal road performance, it may be desirable to employ different cams. On this engine it is comparatively easy to change the camshafts.

It will be noticed that opposite the end of each camshaft a cap is fitted to the side of the crankcase. To withdraw the camshafts, remove the engine oil filler, timing case cover, magneto sprocket, exhaust and inlet sprockets and the chain tensioner. Remove the three screws holding each of the camshaft end caps, compress the valve springs and withdraw the shafts. It will be necessary to rotate the shaft back and forth a little while withdrawing it since it will come out only when it is in a certain position. Also, when replacing the shafts, hold the inlet and exhaust tappets on the driving side out of the way.

- 51 **Brakes.** Brake adjustment has already been dealt with and there is little to say except that Royal Enfield front brakes have their cam spindles mounted in the cover plates in such a manner that they are not rigidly anchored, but are free to float within a certain limit. This means that when the brake is applied, the shoes centralise themselves and make positive contact with the drum surfaces all round.

Should more rapid wear of the lining on the leading shoe be noticed, this does not indicate a fault. It is due to the servo action of this shoe and is to be expected.

- 52 **Wheel Removal.** For the rear wheel this is greatly facilitated by the detachable rear mudguard. By undoing four nuts securing the mudguard stays to the frame, the mudguard may be lifted away.

Petrol Tank Removal ("Constellation"). Turn off the petrol, detach the petrol pipe, remove the front tank holding bolt. Remove the 2 bolts from the rear tank fixing stay.

- 53 **Removal of Rear Mudguard Unit.** The rear mudguard, mudguard carrier and dual seat are removable in one unit after merely slackening the two nuts on the inside of the rear suspension top fixing brackets. Stand behind the machine, grasp the lifting handles on each side and pull the mudguard assembly upwards until the attachment brackets are clear of their respective nuts. Now pull backwards until the clip at the front of the mudguard carrier is free from the backstay bridge tube of the frame, when, after disconnecting the rear light cable, the complete assembly can be removed.

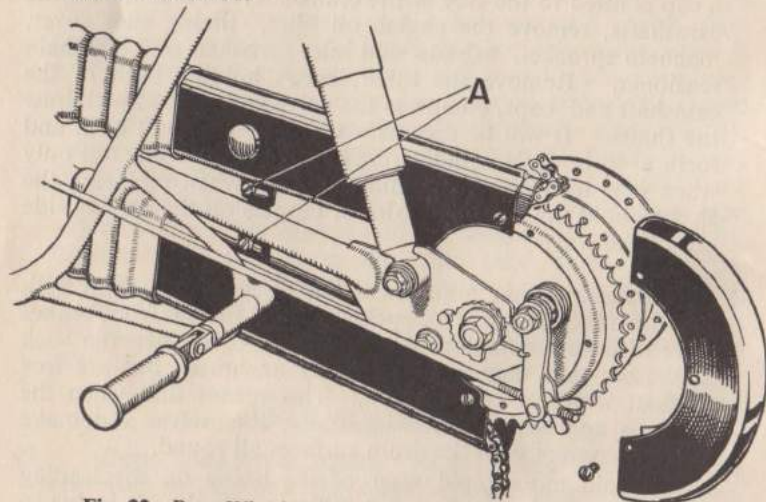

Fig. 22—Rear Wheel Adjustment, showing movement of Rear Chaincase and detachable part of Chaincase "exploded" (where fitted).

When replacing, engage the front clip first and drop the assembly into position. When tightening the nuts make sure that the shoulders of the nuts are right home in the recesses on the inside of the carrier attachment brackets.

When pannier bags are fitted the pannier frame must be removed by undoing the nuts which secure it to the frame in the same place as the normal mudguard stays are fixed. All that then remains to be done is to remove the adjusting nut from the brake rod, disconnect the rear chain by removing the spring link, disconnect the speedometer cable, loosen the spindle nuts and draw the wheel from the fork ends.

To remove the front wheel, place the machine on the stand, disconnect the front brake cable, take the caps from the fork ends by removing their securing nuts, lift the front of the machine slightly and the wheel will fall clear.

- 54 **Quickly Detachable Rear Wheel Removal.** Place the machine on the centre stand and remove the detachable rear mudguard. Unscrew the right-hand spindle nut and withdraw the loose section of the spindle together with the chain adjuster cam, preferably marking this to ensure that it is replaced in the same position. Slide the distance collar out of the fork end and lift away the speedometer drive gearbox which can be left attached to the driving cable. Remove the spacing collar and felt washer. The main body of the wheel can now be pulled across to the right-hand side of the machine, thus disengaging the six driving pins from the cush drive shell and enabling the wheel to be lifted out of the machine.

When replacing the wheel reverse the foregoing procedure, taking care, when replacing the speedometer drive gearbox, that the driving dogs inside the gearbox engage with the slots in the end of the hub barrel. Before tightening the centre spindle make sure that the speedometer drive gearbox is correctly positioned so that there is no sharp bend in the driving cable.

To remove the wheel complete with sprocket and brake drum first disconnect the rear driving chain and remove the brake cover plate anchor nut and the brake adjusting wing

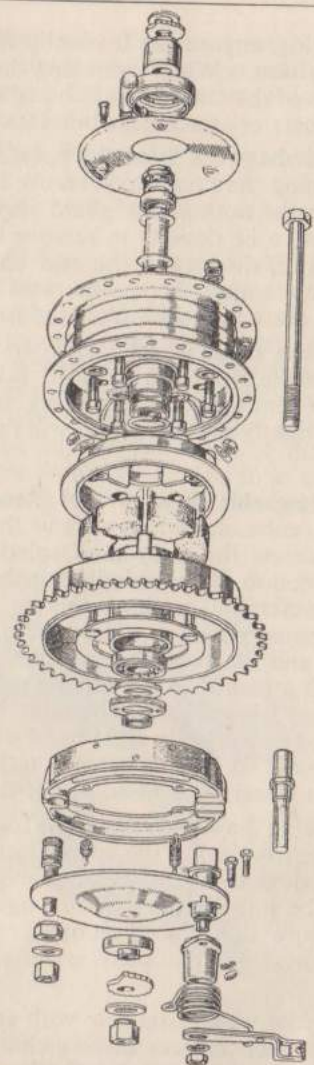

Fig. 23—Exploded view of Q.D. Rear Hub.

nut. Unscrew the loose section of the spindle two or three turns and the left-hand spindle nut by a similar amount. Disconnect the speedometer driving cable and slide the wheel out of the fork ends, tilting it so as to disengage the end of the brake shoe pivot pin from the slot in the fork end.

- 55 **Fitting a New Rear Chain.** Place the machine on the centre stand and remove the rear section of the rear chaincase after unscrewing the three screws holding it to the rear brake cover plate. Disconnect the chain at the connecting link, join up the new chain to the old one and pull it into the chain case by pulling out the old one. Disconnect the old chain and join up the new one, making sure that the closed end of the spring clip points in the direction of travel of the chain. Check for correct chain tension and, if necessary, adjust.

- 56 **Removal of Tyres.** The wired-on tyres fitted are easily removed if the correct procedure is adopted. Deflate the tyre by unscrewing the inside of the valve with the key formed on the dust cap. Remove the milled locknut securing the valve to the rim. At a point opposite the tyre valve, press the walls of the tyre down into the well in the centre of the rim, and work the walls down into the well as far as possible in either direction. It will then be found possible to lever the cover off, starting at a point near the valve and working in either direction. When replacing the cover reverse this procedure, starting opposite the valve and finishing close to it with the tyre at the opposite side of the wheel pressed down into the rim. When only slightly inflated, see that the wired edges are in their proper places, not down in the well. As a check on this, examine the fine line moulded on the wall of the tyre near the rim. This should be about a quarter of an inch from the rim, all the way round.

It is not always appreciated that punctures in the rear tyre can be repaired with the wheel in position. If the puncture is caused by a nail or similar object, whose position

is known, it will be found convenient to remove the mud-guard, leave the wheel in position, remove one side of the cover and expose sufficient of the tube to enable the puncture to be repaired.

When a pillion passenger is carried or when a sidecar is attached, tyre pressure should be increased to carry the extra load. The precise pressure for each wheel will depend upon the load on that particular wheel, but we give the following recommendations of minimum pressures for the guidance of owners.

Front : 18 lb. per sq. in.

Rear : 22 lb. per sq. in.; if pillion passenger carried,
32 lb. per sq. in. approx.

With Single-Seater Sidecar :

Front : 22 lb. per sq. in.

Rear : 25 lb. per sq. in.

Sidecar Wheel : 16 lb. per sq. in.

If a pillion passenger is carried in addition to a sidecar then the rear tyre pressure should be increased to not less than approximately 32 lb. per sq. in.

"DON'TS" FOR DRIVERS

DON'T let in the clutch with a jerk. This practice places unfair strains on the engine, transmission and tyres.

DON'T leave the brakes alone till the last moment and then have to apply them hard. This is only inviting skids and shortening the life of your tyres.

DON'T slam the throttle open suddenly. Give your machine an easy life and it will repay you.

DON'T slip the clutch to save changing gear. The clutch is for use, but this is abusing it.

DON'T be afraid of the lower gears. They are also for use. On the other hand—

DON'T race the engine in a low gear when it will readily pull a higher one. This is abuse.

DON'T try to economise in grease or oil. They are cheaper than repair bills.

DON'T neglect the essential adjustment, particularly the tappets and the clutch control. If you do—

DON'T blame the makers for the inevitable consequences.

DON'T run your tyres too soft. They are expensive, but air is cheap.

DON'T hesitate to consult our Service Department at any time.

MOTOR CYCLE GUARANTEE

The following is a copy of the Guarantee given by Dealers in Royal Enfield Motor Cycles:

CONDITIONS OF SALE AND GUARANTEE

We give the following guarantee with our Motor Cycles which is given in place of any implied conditions or warranties or any liabilities whatsoever, statutory or otherwise; no guarantee except that hereinafter contained and no condition or warranty whatsoever, statutory or otherwise is given or is to be implied, nor are we to be under any liability whatsoever except under the guarantee hereinafter contained. Any statement, description, condition or representation contained in any catalogue, advertisement, leaflet or other publication shall not be construed as enlarging, varying or overriding anything herein contained.

WE GUARANTEE, subject to the conditions mentioned, that all usual and reasonable precautions are taken by us in the manufacture of our Motor Cycles and we will supply free of charge a new part in exchange for any part proved to be defective within six months from the date of purchase. We do not undertake to replace or refix, or bear the costs of replacing or refixing any such new part of the Motor Cycle. As Motor Cycles are easily liable to derangement by neglect or misuse, this guarantee does not apply to defects caused by fair wear and tear, misuse or neglect.

The term "misuse" shall include amongst others the following acts:

1. The attaching of a sidecar to a Motor Cycle in such a manner as to cause damage or calculated to render the latter unsafe when ridden.
2. The use of a Motor Cycle or of a Motor Cycle and sidecar combined, when carrying more persons or a greater weight than that for which the machine was designed by us.
3. The attaching of a sidecar to a Motor Cycle by any form of attachment not provided, supplied, or approved by us, or to a Motor Cycle which is not designed for such use.

We do not guarantee any accessories or component parts supplied to the order of the Purchaser differing from those comprised in the standard specification supplied with our Motor Cycles.

Parts of proprietary manufacture and components not manufactured or processed by us do not come within the terms of this guarantee. Such parts are normally guaranteed by the respective manufacturers to whom any claim should be made in the event of any such part proving defective.

CONDITIONS OF GUARANTEE

If a defective part should be found in our Motor Cycles or in any part supplied by way of exchange as before provided, it must be sent to us, CARRIAGE PAID and accompanied by an intimation by the owner that he desires to have it repaired or exchanged under the guarantee and he must also furnish us at the same time with the number of the machine, date of purchase or the date when the alleged defective part was exchanged as the case may be.

Failing compliance with the above, such articles will lie at our Works at the RISK OF THE OWNER and this guarantee, warranty or condition shall not be enforceable.

REPAIRS

Any Motor Cycle sent to us to be plated, enamelled or repaired will be repaired upon the following conditions, i.e., we guarantee that all usual and reasonable precautions are taken by us in carrying out such work, such guarantee to extend and be in force for three months only from the time such work shall have been executed, and this guarantee is in lieu and in exclusion of all conditions and warranties statutory or otherwise and all liabilities whatsoever and our responsibility is limited to the cost of any further work which may be necessary to amend and make good any work found to be defective.

No guarantee, condition or warranty of any kind, statutory or otherwise, is given or is to be implied, nor are we to be under any liability whatsoever in respect of any machine: (a) which has been used for "hiring out" purposes, or (b) any Motor Cycle used for dirt track, cinder track or grass track racing or competitions of any kind, or (c) from which the trade mark, name or manufacturing number has been altered or removed, or (d) any machine in which parts have been used not supplied by or approved by us, or (e) any machine from which the silencing system as fitted by us has been wholly or partially removed or interfered with.

NOTICE

We do not appoint Agents for the sale on our behalf for Motor Cycle or other goods, but we assign Motor Cycle Dealers areas in which we supply to such Dealers for re-sale in such areas. No such Dealer is authorised to do any business, make any representations or incur any liability on our behalf.

